



# FDH50 Series

## Electromagnetic Door Holder



The FDH50 is an electromagnetic door holder that is suitable for floor and wall mount applications. With low current consumption, the door holder has a holding force of up to 45kg.

The FDH50 accepts voltages of either 12 or 24VDC and is fire rated up to 4-hours to Australian Fire Test Standards\*. The FDH50 is a compact, highly durable electromagnetic door holder suitable for most swing doors.

## Features

- Dual voltage field selectable (12VDC/24VDC)
- Emergency Release Button / Test Button
- Suitable for Floor / Wall mount applications
- Up to 4-hour fire rated in accordance with AS1905.1:2015 (contact Allegion for more details)\*
- Reliable Fail-Safe Mechanism
- Up to 45kg holding strength
- Durable and silent operation
- Compact Size for most types off swing doors

Warranties	
Mechanical	5 years
Electronic	5 years

# Technical specifications

Model	FDH50
Function	Floor/wall mount for swing doors
Holding strength	Up to 45kg
Volatage / Current	Dual voltage 12VDC/100mA    24VDC/50mA
Approvals	4 hour Fire rated to Australian Fire Test Standards*

## Dimensions and mounting details

### Floor Mount

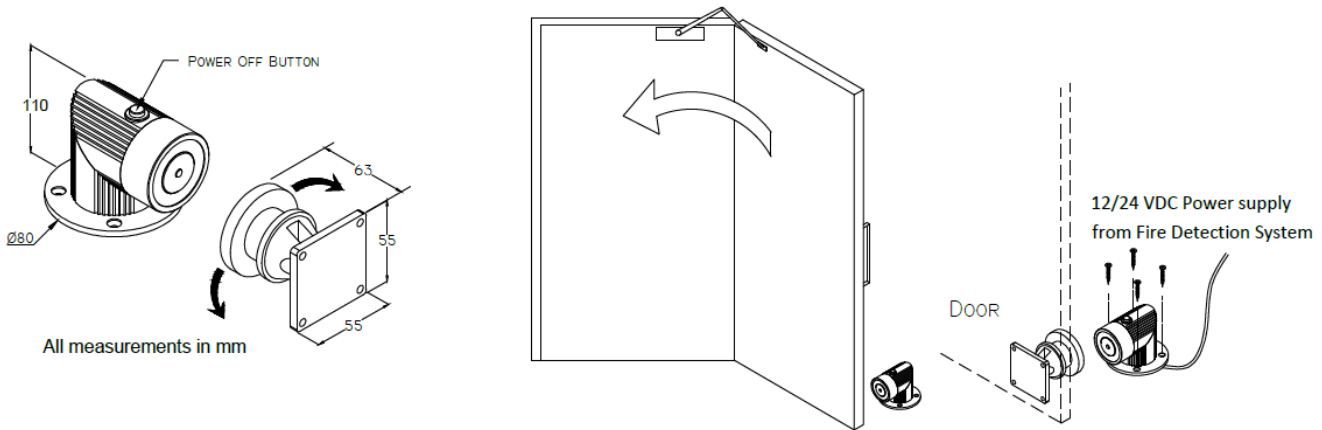

### Wall Mount

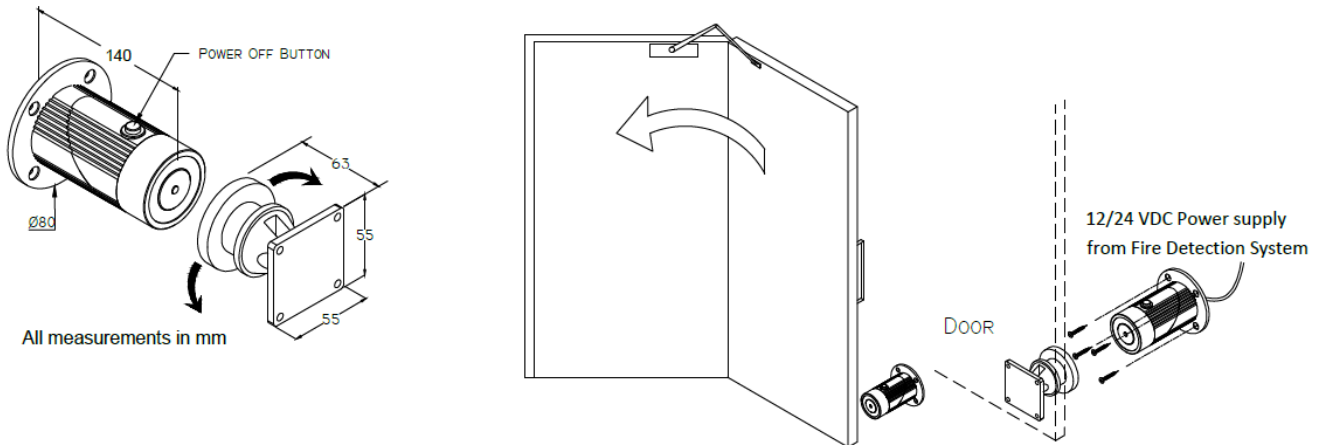

## Testing and Compliance



**Fire:**  
Tested to 4 hours on fire door assemblies as specified in AS1905.1:2015 (contact Allegion for more details)

\*When used with the supplied B110DH Armature Plate