

FSH FSS1
High Security Sensors



SECURITY
C **UL** US
LISTED
EQUIPMENT
BP21118

ALLEGION

FSH is an Allegion™ company

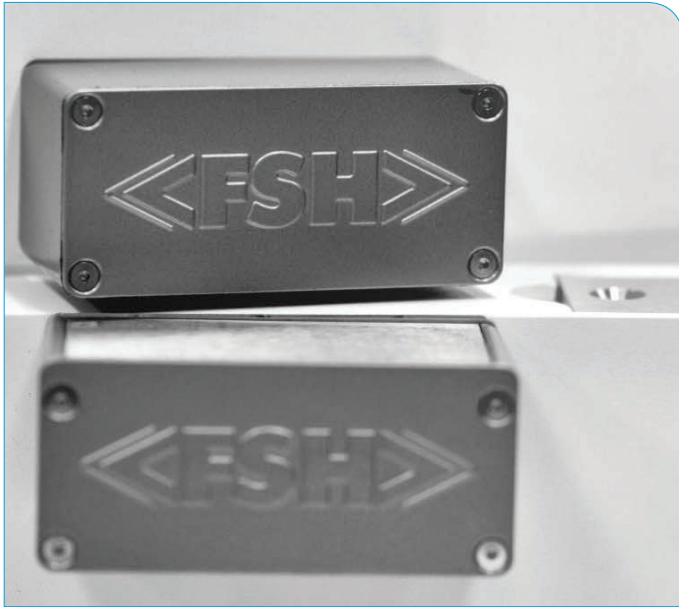

FSS1 SERIES

PRODUCT DESCRIPTION



The FSS1 Series of High Security Door Monitoring Sensor are designed to provide a true high security solution for door position monitoring.

It is a state-of-the-art monitoring solution with a flush mount version for new construction, and surface mount version as a superior replacement for traditional magnetic balanced reed sensors.

Specifically developed for high security applications in government, high risk and defence installations, the FSS1 Series High Security Door Monitoring Sensor consist of seven magnetic sensors that are used to detect a unique magnetic footprint from an array of magnets on the magnetic face plate. One sensor is used to detect the position of the magnetic face plate in relation to the device, while the other six sensors are used to determine the polarity, size, strength and position of the magnets on the unique magnetic face plate in relation to the memorised pattern.

The FSS1 is equipped with sophisticated anti-tamper facilities. The product is listed in the Australian Government Security equipment evaluated Product list (SEEPL) and UL listed to UL 634.2.

TECHNICAL DETAILS

PART NO.	FSS1-S / FSS1-S-NC	FSS1-F
FUNCTION	FSS1-S - Surface mount conduit version FSS1-S-NC -Surface mount no conduit version	Flush mount version (morticed)
VOLTAGE/CURRENT	10 – 30VDC / <45mA	
SECURITY TAMPER PROOF LEVEL	Highest Security Level in Australia (SL4)	
ALARM & TAMPER CONTACTS	2 by N.C. common N.O., 0.2A @ 30V	
DOOR GAP	1-7mm vertical door gap, and up to 15mm door movement for alarm to trigger	
END OF LINE COMPATIBILITY	Space for type 1 & 2 end-of-line encryption modules	
DIMENSIONS	L=75mm H=34mm D=35mm	L=110mm D=32mm W=35mm
APPROVALS	Rated to IP67 RCM Compliant  SCEC Approved, Security Level 4 (SL4) rated 	
ARRAY MAGNETS	Up to 8 magnets for unique magnetic footprint	
HALL EFFECT SENSORS	7	
PATENTS	Patents granted and pending worldwide based on PCT/AU2014/000210	
MANUFACTURE	Designed & Manufactured in Australia	

PRODUCT DIMENSIONS

FSS1-S SURFACE MOUNT CONDUIT VERSION FSS1-S-NC SURFACE MOUNT NON CONDUIT VERSION

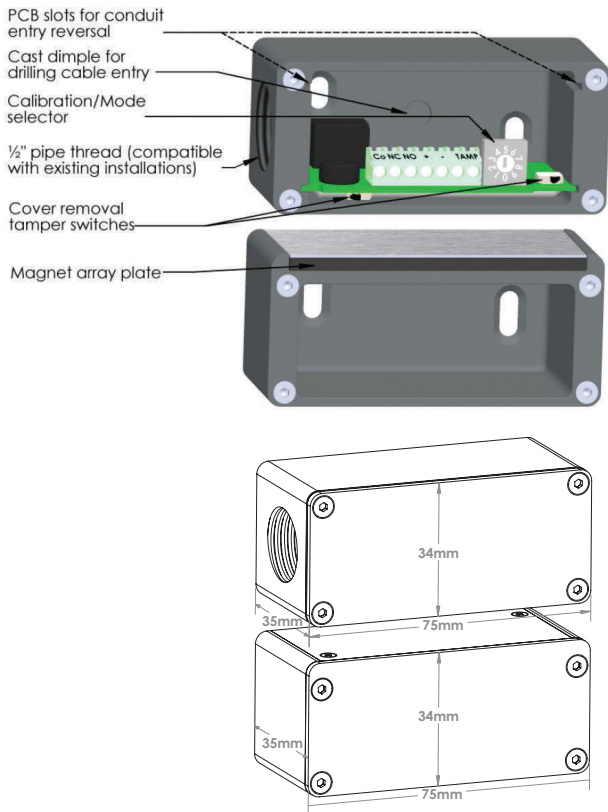

FSS1-F FLUSH MOUNT VERSION

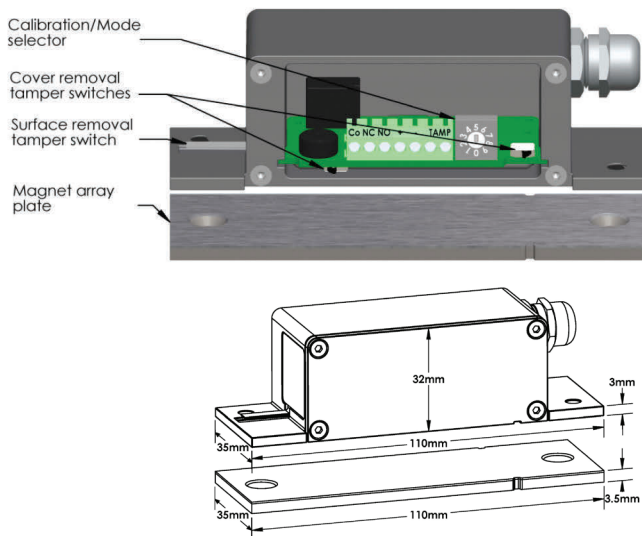



www.fshsensors.net



About Allegion

Allegion (NYSE: ALLE) is a global pioneer in the field of safety and security. We keep people and their property safe, wherever they are, bringing together simple solutions and advanced technology. Allegion is a \$2 billion company, with products sold in almost 130 countries. For more, visit www.allegion.com



ALLEGION™

FSH is an Allegion™ company

Brio ■ <FSH> ■ LCN ■ LEGGE ■ SCHLAGE

© 2018 Allegion