

PRODUCT VE1260
 HIGH SECURITY MOTORISED DROP BOLT WITH PRE-LOAD CAPABILITY **EcoLock**



VE1260

PRODUCT DESCRIPTION

The patented EcoLock VE1260 is a high torque motor driven Drop Bolt with up to 35kg pre-load/ side load tolerance. It can be installed vertically in the door frame (lock style) or horizontally in the frame header and has a symmetric dead-bolt mechanism to allow to be used on 180° degree swing through doors.

The VE1260 is considered a "Green Product" as it consumes an inrush current of 290mA@12VDC **only** during locking and unlocking action (Active Mode), then in the locked or unlocked state (Sleep-Mode), the Drop Bolt consumes current less than 15mA@12VDC.

A series of additional Strike Plates allow for door misalignment of up to ±12mm and a retrofit version of the FSH Eco Lock is available to suit the PADDE/ TRIMEC ES8000 drop bolt footprint.

An optional LED red/green indicator unit is available.

TECHNICAL DETAILS

PART NO.	VE1260
FUNCTION	Mortice Mount, power-to-lock/power-to-release field interchangeable, up to 35kg of Pre-Load capability, locking up to 8kg locking strength
HOLDING STRENGTH	Up to 1000kg (with special bracket)
VOLTAGE/CURRENT	Multi Voltage 12-30VDC Active Mode: Locking/Unlocking cycle current is 0.29A to 0.85A depending on the side load. More side load = more current. Sleep-Mode: After locking/unlocking the current drops down to ~0.015A (15mA)
APPROVALS	CE C-Tick Fire rated in accordance with AS1905.1.2005 Part 1 to up to 4 hours on fire door assemblies
MONITORING	Lock Status Sensor of the internal locking mechanism Door Status Sensor Built-in Reed Switch, monitoring the door position
ENVIRONMENTAL	Operational Temperature Range -20° to +60°C
DURABILITY	Exceeding Australian Standard AS4145.2-2008 400,000 operating cycles • Durability D7
STRENGTH	Meeting Australian Standard AS4145.2-2008 • Static Strength S8 • Impact Strength S8
MAXIMUM DOOR GAP	8mm
DOOR MISALIGNMENT	Standard Strike Plate ± 4mm Special Strike Plate up to ± 12mm

PRODUCT FEATURES

- Releases with up to 35kg of Pre-Load/Side Load (3-wire mode)
- Motorised locking device
- Durability tested to 400,000 cycles
- Multi voltage from 12 to 30VDC
- Sleep-Mode Current less than 15mA@12VDC
- Fully monitored including Reed Switch for door position
- Up to 1000kg Holding Strength
- 5 year warranty
- Retrofit version for Trimec/PADDE ES8000 (VE1260S Square Edge Version)

PRODUCT DIMENSIONS AND INSTALLATION

VE1260R Round Edge

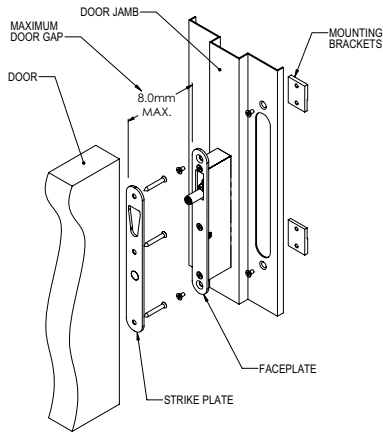

VE1260S Square Edge

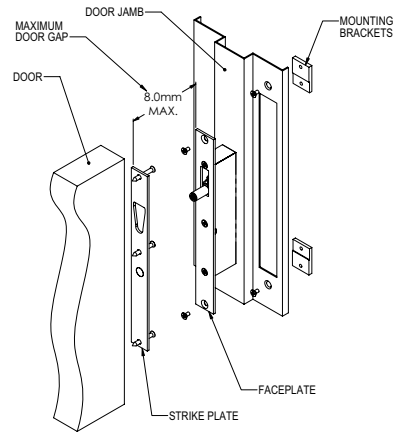

Locking Device VE1260R Round Edge

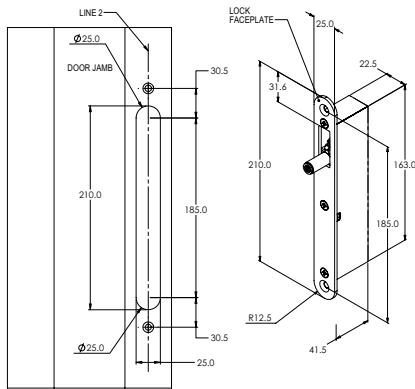

Locking Device VE1260S Square Edge

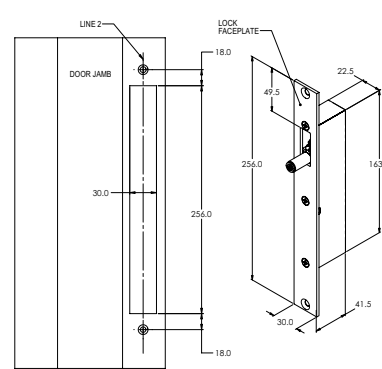

Strike Plate VE1260R Round Edge

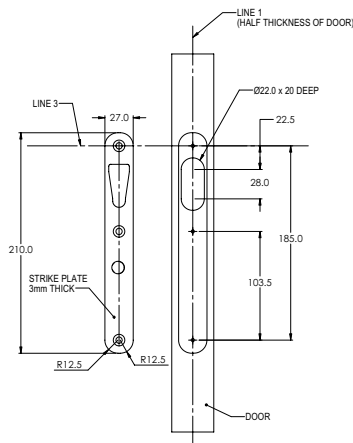

Strike Plate VE1260S Square Edge

